



SOLBERG
Filtration & Separation

Vacuum Trap

VTL Series, VTS Series

Application

Solberg's vacuum traps can be used to protect a variety of vacuum pump technologies from particulate, liquid, aerosol and vapor contaminants migrating from a process. Multiple insert options and configurations are available to ensure pumps are properly protected. The trap minimizes pump oil contamination resulting in significantly fewer oil changeouts and reduced maintenance costs.

Benefits

- Prevent back streaming
- Remove hydrocarbons
- Trap condensable vapors
- Reduce overall maintenance costs
- Chemical resistant
- Easy maintenance

Features

- All Stainless Steel construction
- No tools needed to separate housing hemispheres with the quick release v-band for ease of maintenance
- Integrated drain port
- Connections available NW-16, 25, 40, 50

Technical Specifications

- Vacuum service down to 1×10^{-3} Torr
- Leak rate: 1×10^{-7} mbar L/S
- Temperature range -20°C to 150°C
- Fine bead blast finish
- Viton o-ring



VTL Series



VTS Series

Rev: VTL/S-US1807K

Series Options:

Molecular Sieve

- Traps water vapor and other gases
- Rechargeable 13X Zeolite desiccant
- Integral 120 VAC or 240 VAC regeneration heater
- Reduce oil change-out

Metal Wool

- Trap hydrocarbons and large particulate
- Replaceable Stainless Steel or copper insert
- Reduce contamination

Chemical Adsorbents

- Trap chemicals and corrosives
- Chemical compatible adsorbents available (ie: activated carbon, alumina, SodaSorb, etc.)
- Reduce hazards

Fine Particulate

- Trap fine particulate
- Multiple media available (down to .2 micron at 99.99% efficiency)
- Reduce dust and particle ingestion

VTL Housing Size	Dimensions - inches				
	A	B	C	D	E
4"	4	5 ¼	7 ½	1 ½	6 ⅔
6"	6 ⅞	7 ¼	9 ¾	2 ½	8 ⅓
8"	7 ⅞	9	11	3 ¼	10 ½

VTS Housing Size	Dimensions - inches		
	A	B	C
4"	4	5 ⅓	11 ¼
6"	6 ⅞	7 ¼	11 ¼
8"	7 ⅞	9	11 ½

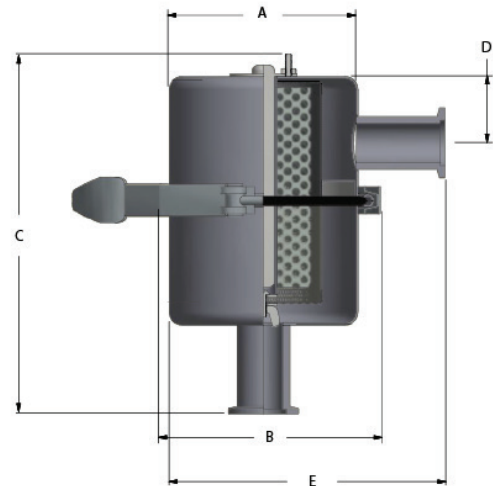

VTL Configuration

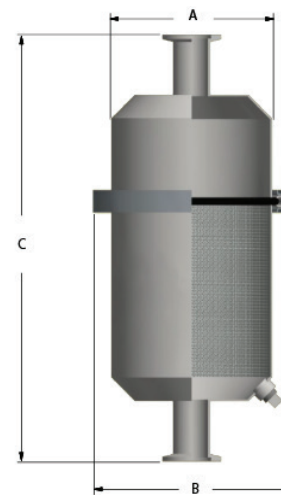

VTS Configuration

NOTE : When unable to achieve base pressure, the operator should regenerate the sieve by turning on the heater for a few hours and running the mechanical pump with its ballast valve open. The frequency and duration of sieve regeneration depends on the kind and amount of gas(es) produced by the particular application.



SOLBERG

All model offerings and design parameters are subject to change without prior notice. Contact your representative or Solberg for the most current information.

www.solbergmfg.com