

Biogas Engine Applications

The Challenge

A California based anaerobic digester developer needed a cost effective closed crankcase ventilation system that was tailored to fit Caterpillar 3516 engines. The engines are used for Biogas energy applications for dairy farms and other commercial facilities. Their previous set up required two units per engine and expensive custom adapter plates for attaching their existing units. Finding an off the shelf solution with a proven track record and working with a hands-on partner to provide a more cost-effective solution were the key decision drivers for the developer.

The Solution

Solberg offered its ACV Series Advanced Crankcase Ventilation System as an economical solution with a one-piece bracket that bolts directly to the engine. The standard Solberg ACV system and bracket were supplied requiring no additional adapter plates, simplifying the install. A customer specific kit was created allowing the developer to easily reorder components for future projects.

Results

With the ACV retrofit, the developer was able to reduce their overall cost on the crankcase ventilation system while eliminating additional components. The developer was satisfied with the results and has partnered with Solberg for future Bioenergy projects. Based on the success with the ACV project, the developer asked Solberg to assist with cleaning up the raw biogas. Solberg provided multiple stainless-steel liquid knockout filters / gas scrubbers to clean the biogas prior to entering the engine.



Rev: 3516-US1903K

Solberg Products Provided

ACV-1-20-200L-K5
 ACV-1-20-200R-K5
 Advanced Crankcase Ventilation system

ACV Accessory Components consisting of customer specific bracket and 90 degree elbows

LRSD-DM14/275-400FS1 Low Pressure Stainless Steel liquid knockouts vessels / particulate scrubbers

The Product

The ACV is designed to protect your engine's turbo, coolers, and inlet air filters as well as help ensure environmental compliance while keeping engine rooms clean, safe & free of oil mist. The series comes standard with industry leading automated vacuum control technology to regulate crankcase pressure and prevent seal leakage. The replaceable filter element contains a proprietary media pack offering exceptional efficiency levels with an extremely long life, allowing operators up to one year before an element change is required.

ACV Design Features

- Eliminates visible emissions (99%+ efficient at 0.3 um)
- High performance coalescing elements offer long life
- Flow ranges from 2 - 40 CFM (3 - 68 m³/hr) for single units
- Integrated vacuum control valve controls precise range of vacuum
- Diaphragm vacuum regulation valve design, no springs; No manual vacuum adjustment required
- Drain port for oil recovery
- Universal mounting bracket
- Available with installation kits
- Optional atmospheric bypass

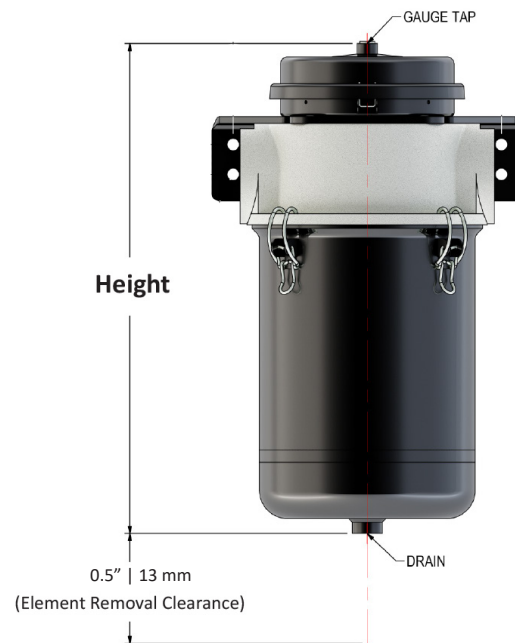
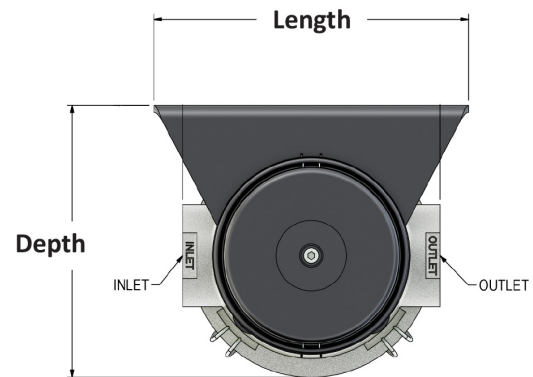

PART NUMBER	ACV-1-20-200L
INLET/OUTLET	2" NPSC
DRAIN	.5" NPSC
GAUGE TAP	.25" NPSC
FLOW RATE	20 CFM 34 m ³ /hr
HEIGHT	23.3" 567 mm
LENGTH	11" 279 mm
DEPTH	9.5" 241 mm



SOLBERG

www.solbergmfg.com

All model offerings and design parameters are subject to change without prior notice. Contact your representative or Solberg for the most current information.