

Wartsila 9L20 Diesel Marine Engines

The Challenge

A new super yacht being powered by one Wartsila 9L20 was being built in the Netherlands. Solberg was contacted to provide an oil mist eliminator to remove and recover the oil mist coming out of the crankcase.

The Solution

Solberg chose a vertical recirculation type system to meet their needs. This type of system is self-balancing, does not add any additional pressure or vacuum, and does not require any adjustments. Not requiring adjustments is ideal for the marine market as engines can operate under various loads which can alter the amount of crankcase blowby. This unit was painted specifically to match the rest of the engine room and installed in 2015. The Solberg Crankcase Ventilation System has been successfully capturing oil mist emissions since installed.



Solberg's Crankcase Ventilation System

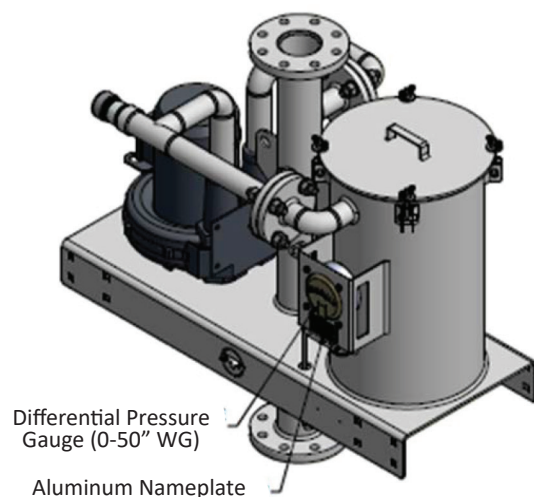

Rev: W9L20-US1810K