

REV	DESCRIPTION	ECN #	CHG BY	DATE	APP'D
A	UPDATED P/N, WAS CSL0001836	32169	MJF	03/04/25	EZR

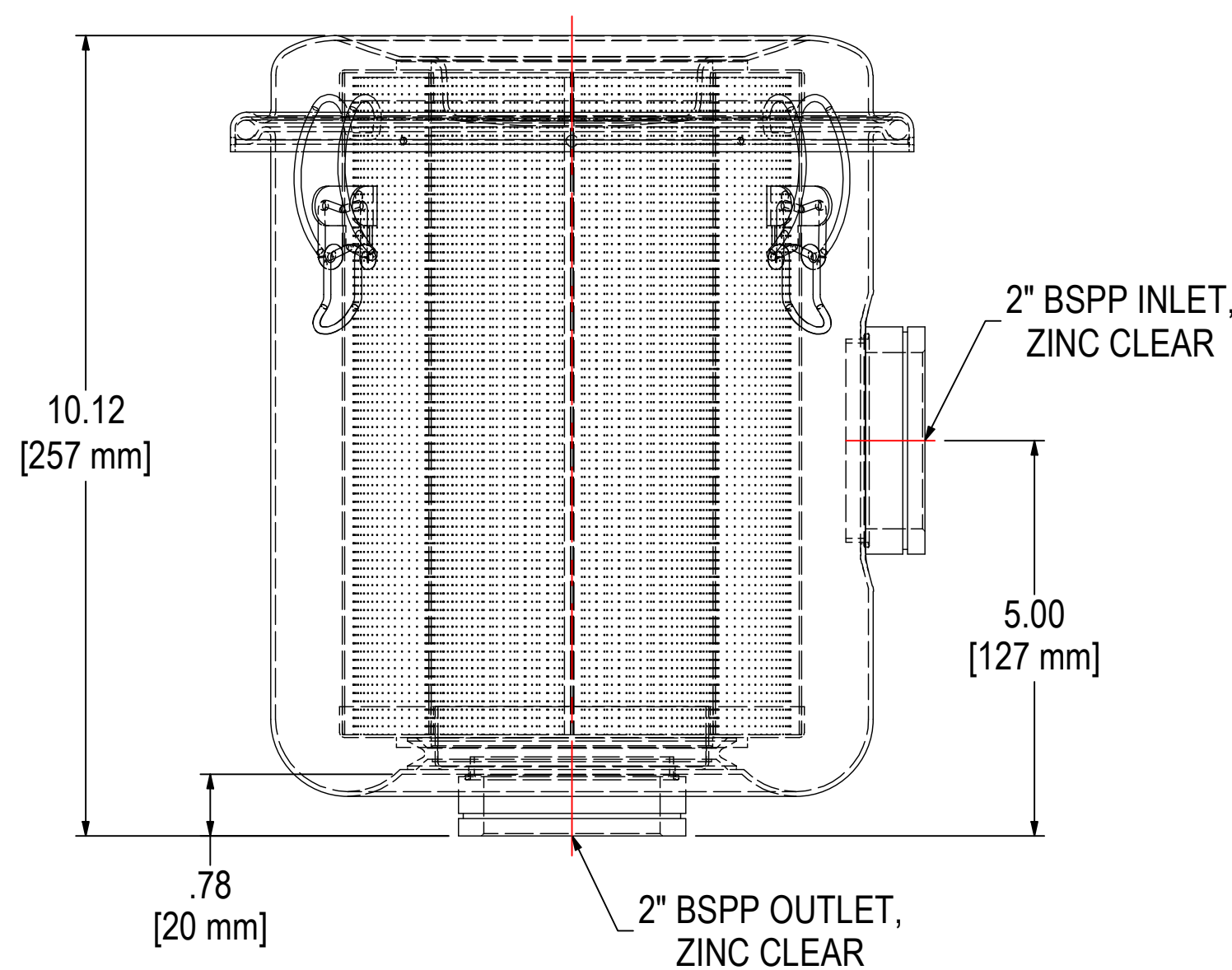

ELEMENT SPECS		
PART NUMBER	850	
MATERIAL	PAPER	
FLOW RATE	290 CFM	493 m ³ /hr
SURFACE AREA	13.1 ft ²	1.2 m ²
I.D.	3.50"	89mm
O.D.	5.88"	149mm
HEIGHT	8.69"	221mm

MODEL #: CSL-850-201KCB	MATERIAL: CARBON STEEL	FINISH: BLACK POWDER
MODEL NUMBER: CSL-850-201KCB	SHEET: 1 OF 1	
DESCRIPTION: CSL-850-201KCB, BLACK		
PROJECT:	DRAWN BY: EZR DATE: 3/19/2024	APPROVED BY: JSR DATE: 3/25/2024
		REV: A

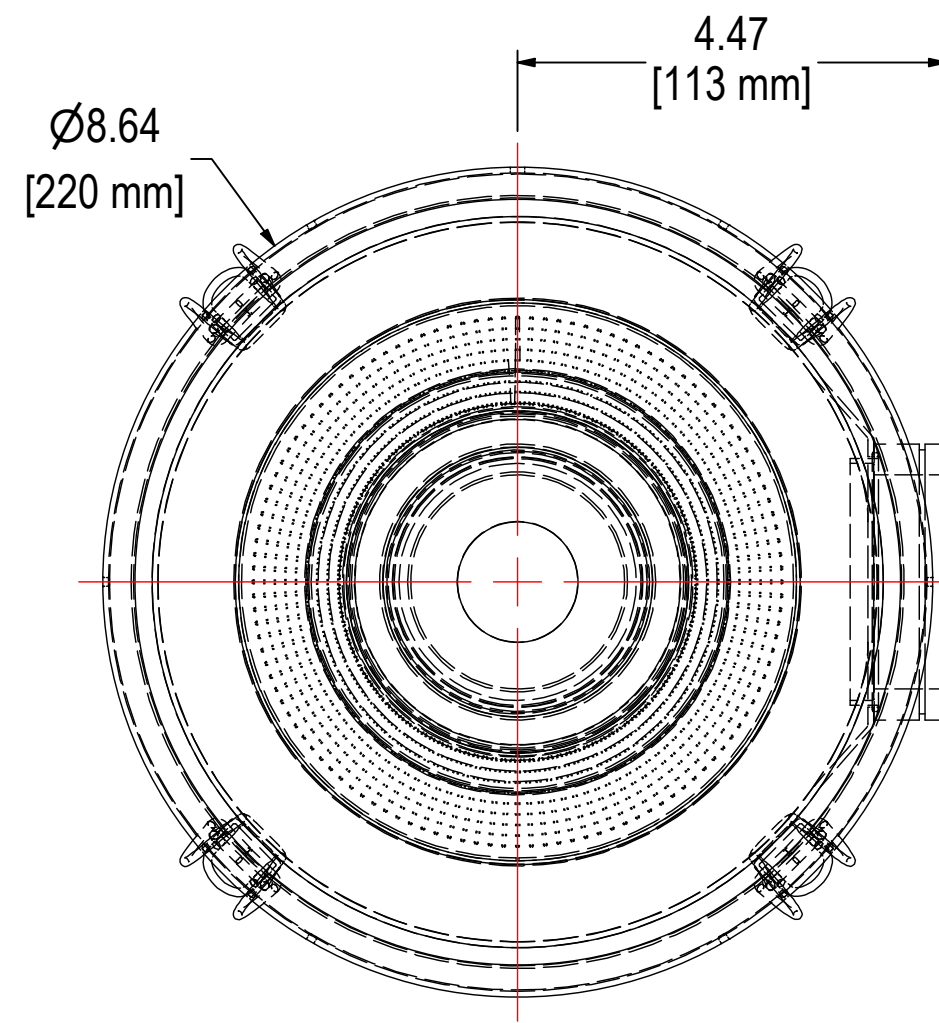

THE INFORMATION CONTAINED HEREIN IS CONFIDENTIAL AND THE PROPERTY OF SOLBERG MANUFACTURING INC. AND IT IS FURNISHED TO YOU WITH THE EXPRESS UNDERSTANDING THAT IT WILL NOT BE REPRODUCED, COPIED IN ANY MANNER, LOANED OR OTHERWISE TRANSFERRED TO OTHERS ENTIRELY OR IN PART, NOR USED FOR ANY PURPOSE OTHER THAN FOR WHICH IT WAS FURNISHED. IT WILL BE RETURNED UPON REQUEST TO SOLBERG MANUFACTURING INC. THE ABOVE RESTRICTION IS IN ADDITION TO, AND DOES NOT IN ANY WAY ALTER, ANY OTHER RESTRICTIONS WHICH MAY APPLY TO THE INFORMATION CONTAINED HEREIN.

TOLERANCES
DIMENSIONS ARE FOR REFERENCE ONLY. ALL DIMENSIONS ARE SUBJECT TO CHANGE UPON PRODUCTION.
UNLESS OTHERWISE SPECIFIED:
-DIMENSIONS ARE IN INCHES
-REF: APPROXIMATE DIMENSIONS, NO TOLERANCES APPLY
-FINISH: BREAK EDGES TO .005-.020 RADIUS/CHAMFER